

GREENWAY[®]

PRECISION CNC LATHE



昌勇實業股份有限公司
JARNG YEONG ENTERPRISE CO., LTD.

本公司之產品規格，設計特性均不斷研究改進，規格若有變更，恕不另行通知。

All specifications, dimensions and design characteristics shown in this catalogue are subject to change without notice.



公司介紹

本公司成立於 1978 年，發跡於機械滑板製造加工廠，隨著公司的成長進而轉型為車床製造商。透過嚴密的品質要求及完善的服務精神，至今所生產的自動車床及CNC車床已銷售逾40個國家，市場給予高度的肯定。而「服務至上」為客戶提供Total Solution是「昌勇實業」的經營理念，從客製化的產品設計、生產、維修等，從頭負責到尾的完整服務，為的就是以客戶為本，客戶的問題就是我們的問題！

品牌形象 Brand

GREENWAY®

全球的 Global
堅固的 Rigid
精確的 Exact
優良的 Excellent
低噪音 Noiseless

JARNG YEONG ENTERPRISE CO., LTD. was established in 1978, were set to produce mechanical slides and now we are one of the leading manufacturers of CNC and Auto lathes in Taiwan. By providing high quality machines and the best after-service, our lathes are now selling to over 40 countries globally and gained excellent reputation. The main concept of JARNG YEONG is to give our customers a Total Solution. From design to produce, all can be customized. Our customers are what we truly valued!



GREENWAY®

The best for your choice!



JOA-252



HCS-32B



HCS-25



HCP-42



HC-30



HC-30N

HC-30N Economical CNC Lathe 經濟型數控車床

一部絕對超值、穩定、高效益經濟型數控車床，可選擇單件加工或搭配送料機進行無間斷自動加工。

*An economic value model. Stable, high performance and high profit.
Single piece process or to process automatically with bar feeder.*



機型 Model	棒材容納直徑 Max. bar feeding dia	主軸貫穿孔徑 Bore of spindle	主軸鼻端 Spindle nose
HC-30N	Ø30	Ø33	A2-4

選購附件 *OPTIONAL ACCESSORIES*



八位伺服刀塔
8-position servo turret



5" 三爪夾頭
*5" 3-jaw hydraulic
chuck*



成品取料裝置
Parts catcher device



電動螺旋排屑機
*Electrical screw type chip
conveyor*

*** 櫛式刀具配件 STANDARD ACCESSORIES FOR GANG TYPE**



內孔刀架 (內徑 $\varnothing 20$)
Tool holder for inner hole (I.D $\varnothing 20$)



內孔套筒 (外徑 $\varnothing 20$)
(I.D $\varnothing 6,8,10,12,16$ / O.D $\varnothing 20$)
Tool holder bush



上刀架 $\square 20$
Upper tool holder $\square 20$



下刀架 $\square 20$
Lower tool holder $\square 20$

*** 刀塔配件 STANDARD ACCESSORIES FOR TURRET TYPE**

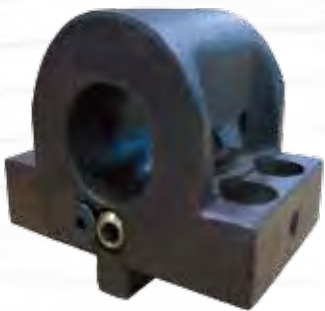

內孔刀座 (內徑 $\varnothing 20$)
Tool base for inner hole (I.D $\varnothing 20$)



內孔刀架 (內徑 $\varnothing 20$)
Tool holder for inner hole (I.D $\varnothing 20$)



車刀墊片 (上、下) $\square 16$
Tool spacer (up,down) $\square 16$



內孔套筒 (外徑 $\varnothing 20$)
(I.D $\varnothing 6,8,10,12,16$ / O.D $\varnothing 20$)
Tool holder bush



機身一體鑄造成型，高剛性
最大X/Z軸行程：X 300mm/Z 200mm
超寬X/Z軸跨距，最穩定
價格經濟，性價比超高

*One piece casting machine body, high rigidity
Max X/Z axis travel for X 300mm/Z 200mm
Widest X/Z axis distance, the most stable
The economical price with high Capacity/Price*

HC-30/HCP-42 Multitasking CNC Lathe

車銑複合數控車床

多種車銑複合組合，搭配側面、端面動力刀具裝置可進行內、外徑車削銑製加工，提高生產力、高效能。

Numerous multitasking combinations. With side/end face live tools devices, allowed to do the I.D and O.D turning/milling to enhance the productivity.



HC-30



HCP-42



(試車影片-Video)

機型 Model	棒材容納直徑 Max. bar feeding dia	主軸貫穿孔徑 Bore of spindle	主軸鼻端 Spindle nose
HC-30	Ø30	Ø33	直結式 direct-connection
HCP-42	Ø42	Ø45	A2-5

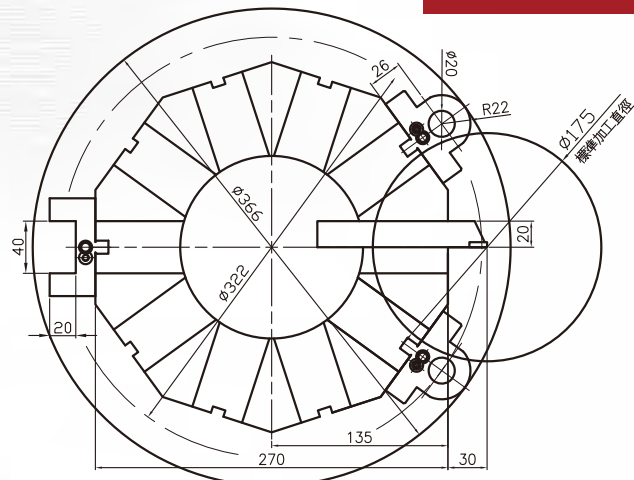

刀塔刀具干涉圖 Turret tool Interference Diagram

*** 依不同需求，選擇搭配 *VARIOUS OPTIONS THAT MEET YOUR REQUIREMENTS!***

*** 上段選配 (UP)**



八位置油壓刀塔
8-position hydraulic turret



Y軸側銑裝置 (ER16)
Y-axis side live tooling device



上方單軸側銑裝置 (ER25)
Single shaft side live tooling device-Top

*** 中段選配 (MIDDLE)**



角度型端銑裝置 (ER16)
Angle-adjustable end milling device(45°)



端銑裝置 (ER16)
End side live tooling device



單軸立式銑刀裝置 (ER20)
Single shaft vertical type live tooling device

*** 下段選配 (DOWN)**

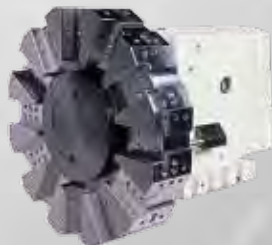

八位伺服刀塔
8-position servo turret



下方單軸側銑裝置 (ER20)
Single shaft side live tooling device-Below

HCS-25/32 Swiss Type CNC Lathe

走心式/走刀式數控車床

高剛性結構車體，可作走心/走刀兩用車床，具有車、銑、攻牙及輪廓等多樣化加工功能，適用於長工件加工，縮短加工製程提高生產力。

High rigidity body, Sliding head CNC lathe with turning, milling, drilling, tapping and contouring functions. Suitable for processing long piece to enhance the productivity.



(試車影片-Video)

機型 Model	棒材容納直徑 Max. bar feeding dia	主軸貫穿孔徑 Bore of spindle	主軸型式 Spindle type
HCS-25	Ø25	Ø28	built-in
HCS-32	Ø32	Ø33	built-in

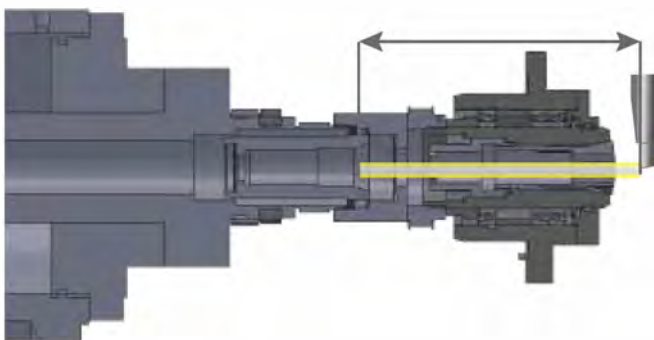

走心式行程180mm，最少殘料150mm
*With guide bush type travel: 180mm,
 Min. Offal: 150mm.*

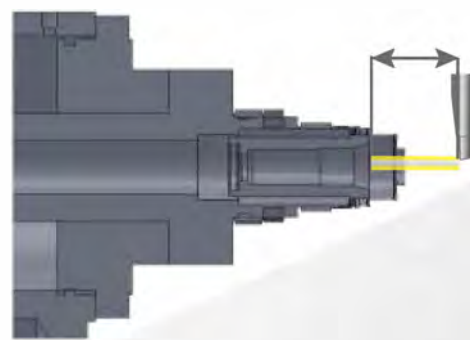

走刀式行程310mm，最少殘料50mm
*Without guide bush type travel: 310mm,
 Min. Offal: 50mm.*

根據不同加工需求，可選擇更換走心式/走刀式組合結構。
The synchronize guide bush can be installed/released according to various processing needs.

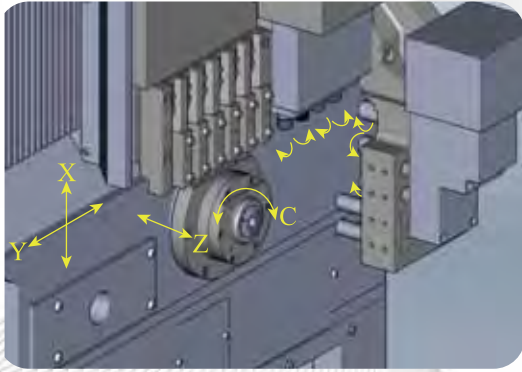

* 刀具排列
* Tools Arrangement

內藏式主軸最高轉速6000rpm，具有C軸功能
Built-in spindle includes C-axis function, max. 6000rpm

油壓迴轉缸提供快速、穩定的夾持力
Hydraulic cylinder provides high speed and stable clamping

高剛性線軌，提供更穩定、快速精確的
加工給進
High rigidity linear guide ways provide
stable, rapid and precise feeds

一體成形底座，高剛性更穩定性
Machine body made from one piece solid cast iron,
high rigidity and stability

X1/Y1/Z1 軸向伺服馬達，快速進給達25m/min
X1/Y1/Z1 axis servo motor, max. rapid feed rate 25m/min

□ 16外徑刀具座
□ 16 External tool holder

端面動力刀具裝置(ER20)最高轉數5000rpm
Axial live tooling, max. 5000rpm

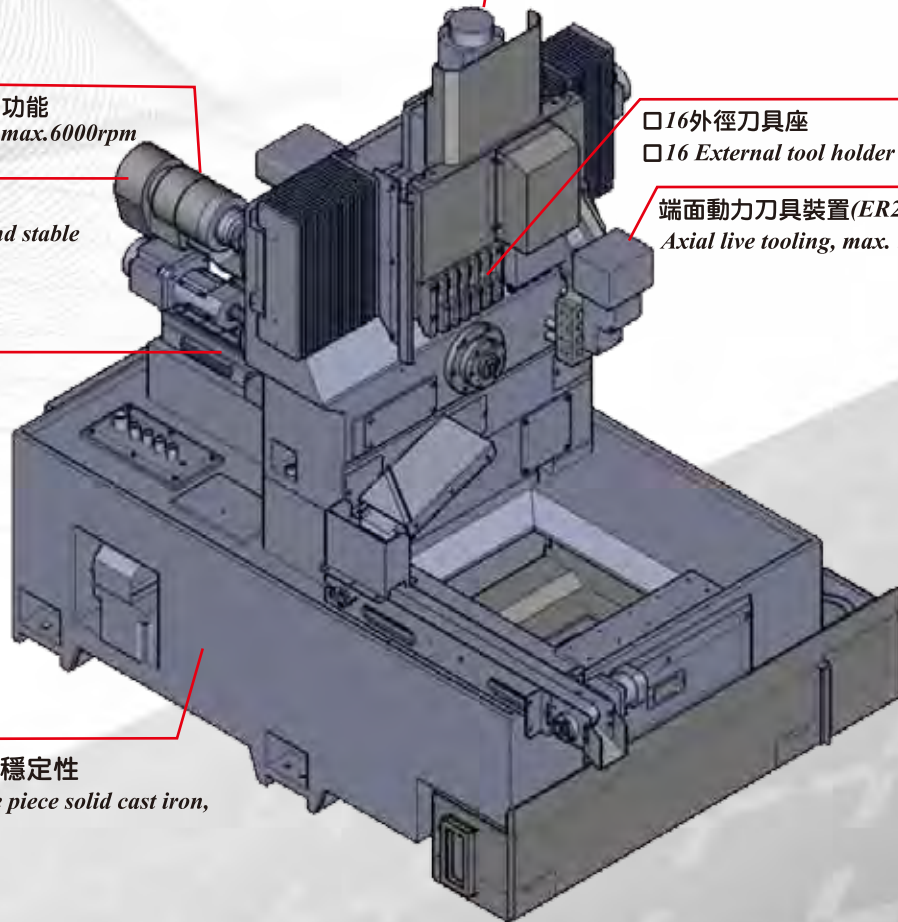

標準配件-同步迴轉導套達成異形加工的需求。
Standard accessory: Synchronize rotary guide
bush device, can process work pieces with various
shapes.



內藏式主軸具備高轉速、大功率、高精度以及
低振動等特性，使加工表面更為細緻平滑。
Built-in spindle: high rotating speed, higher
power, high accuracy and less vibration.
Produce finest finished.

HCS-25B/32B Dual-Spindle CNC Lathe

雙主軸數控車床

雙主軸車床，正面背面同時加工，提高作業效率，亦可選配同步迴轉導套加工長軸型工件，可彈性靈活運用。

Dual-spindle. Can process both sides of the workpiece synchronously to enhance the productivity. Synchronize guide bush can be optional for processing long shaft pieces to reach various needs.

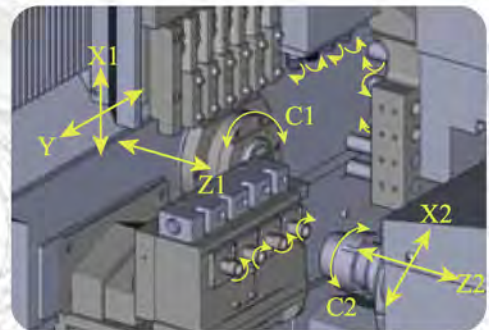

* 刀具排列
* Tools Arrangement

機型 Model	棒材容納直徑 Max. bar feeding dia	主軸貫穿孔徑 Bore of spindle	主軸形式 Spindle type
HCS-25B	Ø25	Ø28	built-in
HCS-32B	Ø32	Ø33	built-in



(試車影片-Video)

副主軸動力刀具裝置由伺服馬達驅動可做背面銑削
Live tools device of the sub-spindle is driven by servo motor to do back-side processing

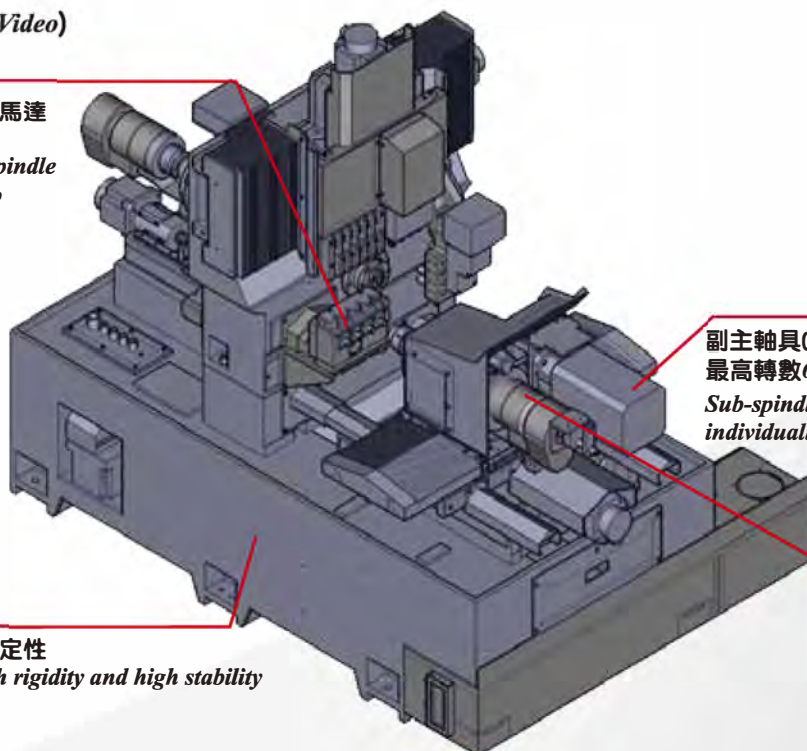

副主軸具C軸功能可獨立加工，由伺服馬達驅動，最高轉數6000rpm
Sub-spindle with C-axis function, allows to process individually. Driven by servo motor, 6000rpm max

副主軸具吹氣及推料裝置
Air blower and parts ejector are installed with sub-spindle

一體成形底座，高剛性高穩定性
One piece machine base, high rigidity and high stability

選購配件 *OPTIONAL ACCESSORIES*



副主軸端面4軸動力刀具裝置
End side 4-shaft live tooling device for sub-spindle



正主軸端面3軸動力刀具裝置
End side 3-shaft live tooling device for main spindle



同步迴轉導套
Synchronous rotary guide bushing device



電動鏈板式鐵屑排出機
Electrical steel belt type chip conveyor

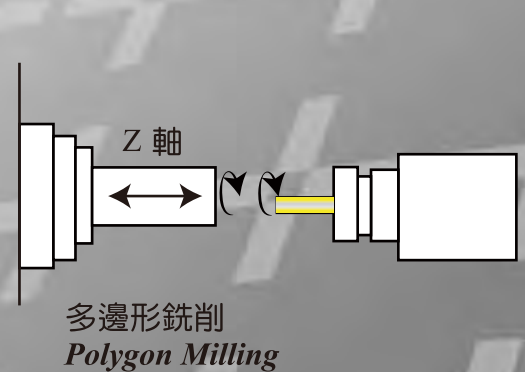
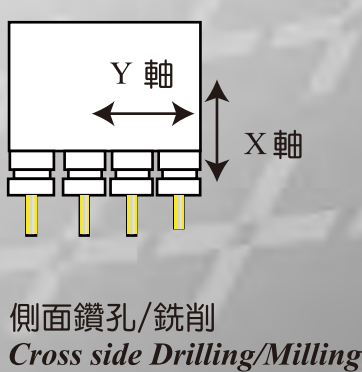
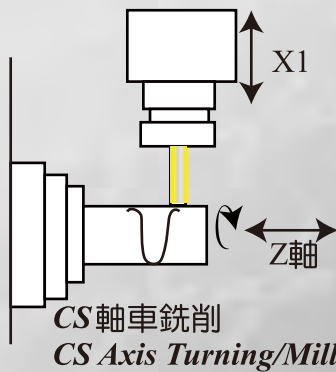
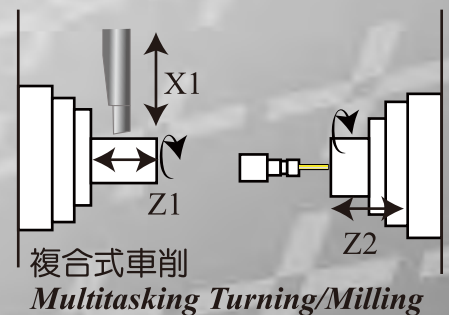
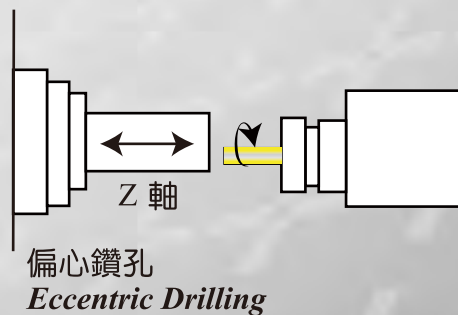
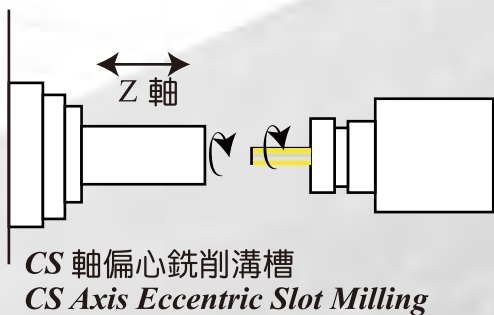
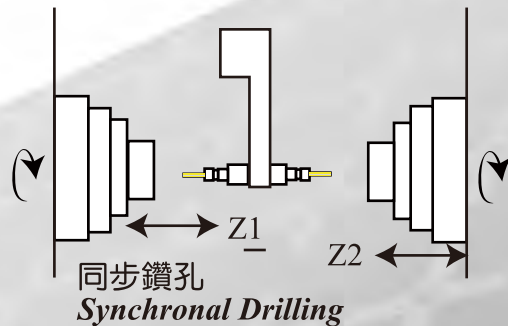
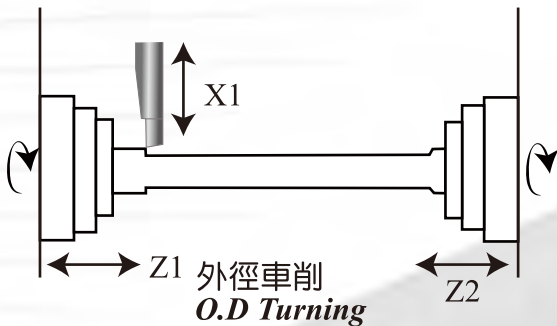

JOA-252 Turret type CNC Lathe 斜背式數控車床

45度斜背式車床結構，X/Z軸方形硬軌設計，搭配十位置高剛性油壓刀塔或選配伺服動力刀塔、低震動低噪音，穩定更耐用。

45° Slant angle of bed, box way designed of X/Z axis with 10-position hydraulic turret or 12-position servo power turret. Less vibration and noise, stable and longer machine life.



可選配12位置伺服動力刀塔
Opt. 12-position servo power turret.



PS. 標準配備 A2-6 8" 三爪夾頭，也可選擇搭配60#筒夾套 (185E筒夾) 或10"三爪夾頭。

Standard accessory: 8" 3-Jaw hydraulic chuck.

Optional accessory: 60#collet chuck (185E collet) or 10" 3-Jaw hydraulic chuck.

	刀塔形式 Turret type	可容納棒材外徑 Bar capacity	最大加工長度 Max. turning length	三爪油壓夾頭 3-jaw hydraulic chuck	筒夾套 Collet chuck
JOA-252	油壓刀塔 / 動力刀塔 Hydraulic / Servo power	Ø52	600mm opt.(900mm) 1200mm	A2-6 8"	-
Opt.-1		Ø60		-	60#
Opt.-2		Ø63		A2-6 8"	-
Opt.-3		Ø75		A2-8 10"	-

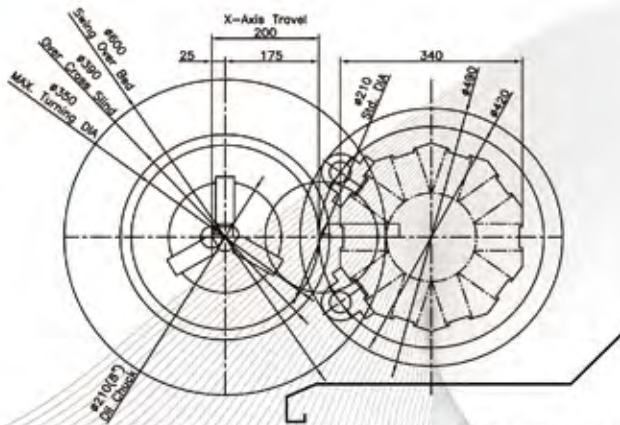

十位油壓刀塔-刀具干涉圖 Tool Interference Diagram (X axis)
10 position hydraulic turret

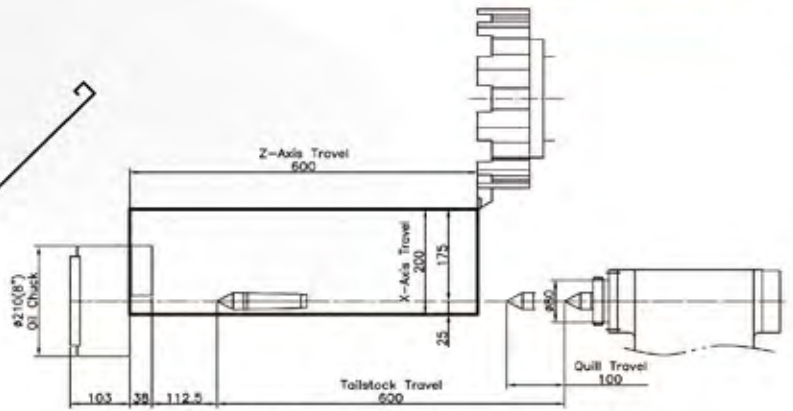

十位油壓刀塔-刀具干涉圖 Tool Interference Diagram (Z axis)
10 position hydraulic turret

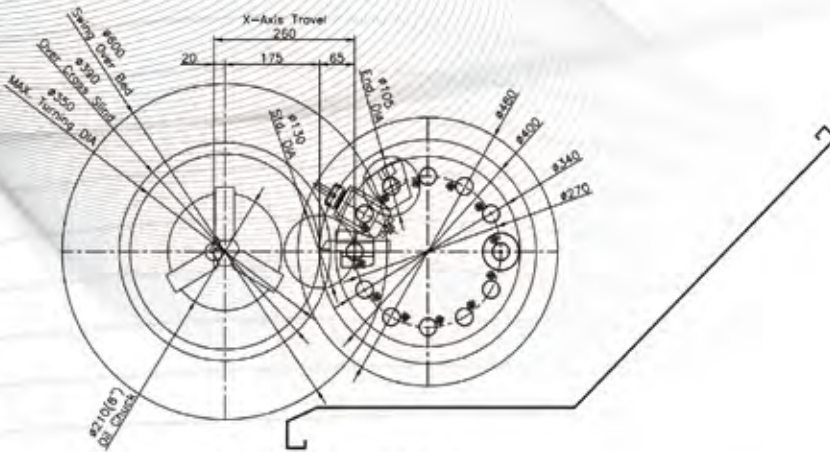

十二位動力伺服刀塔-刀具干涉圖 Tool Interference Diagram (X axis)
12-position servo power turret

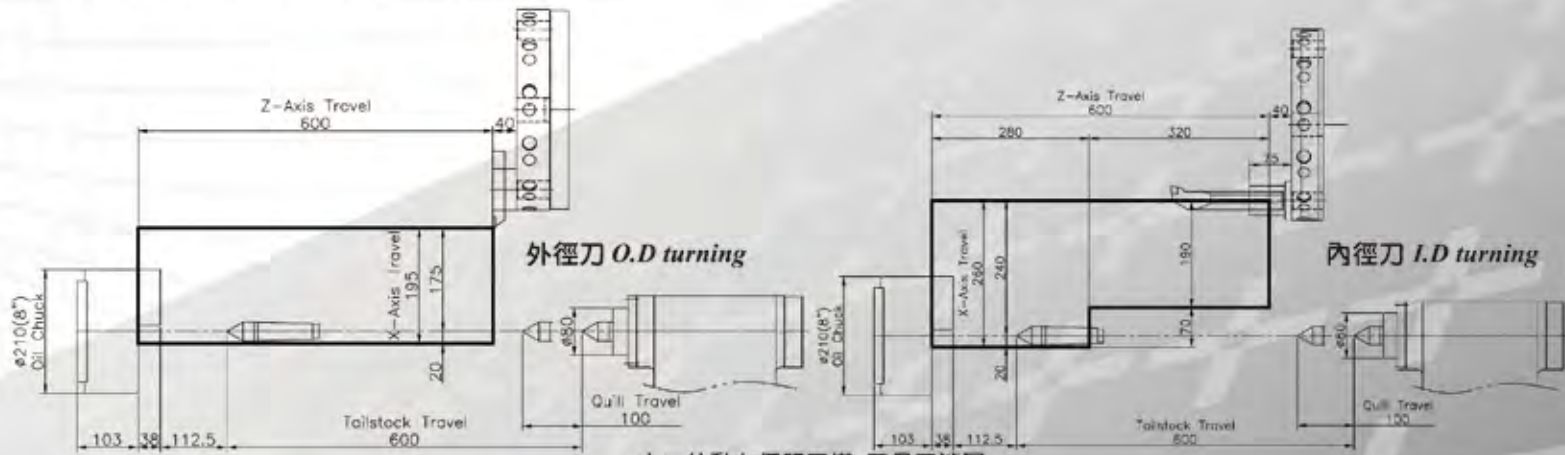

十二位動力伺服刀塔-刀具干涉圖 Tool Interference Diagram 12-position servo power turret



手動刀具量測器
Manual tool measurement



C軸功能-碟刹裝置
C-axis function (Disc brake device)



A2-8 10" 三爪油壓夾頭
A2-8 10" 3-jaw hydraulic chuck



VDI-30 伺服動力刀塔
VDI-30 servo power turret

機械規格 MACHINE SPECIFICATION

機型 MODEL		HC-30	HCP-42
棒材容納直徑 (mm)	Max.bar feeding dia	Ø30	Ø42
主軸貫穿孔徑 (mm)	Bore of spindle	Ø33	Ø45
主軸鼻端	Spindle nose	直結式 Direct-connection	A2-5
筒夾	Collet	163E	173E (C44)
標準加工外徑 (mm)	Standard turning dia.	140	140
最大加工長度 (mm)	Max. turning length	150	150
主軸馬達 (kw)	Spindle motor	3.75 (opt 5.5)	3.75 (opt 5.5)
主軸迴轉速 (rpm)	Spindle rotating speed	50-6000	50-6000
X,Z軸伺服馬達 (kw)	servo motor (X-axis,Z-axis)	1	1
X軸移動量 (mm)	X-axis travel	350	350
Z軸移動量 (mm)	Z-axis travel	250	250
X軸快速移動 (m/min)	Rapid travel speed (X-axis)	20	20
Z軸快速移動 (m/min)	Rapid travel speed (Z-axis)	20	20
外徑刀尺寸 (mm)	O.D. tool size	□20	□20
內徑刀尺寸 (mm)	I.D. turning tool size	Ø20	Ø20
八位置油壓刀塔	8-position hydraulic turret	8位 8 position	8位 8 position
機器尺寸(長x寬x高) (mm)	Machine size (LxWxH)	1800x1450x1660	1780x1600x1800
機械淨重 (kgs)	Machine net weight	2100	2300

HC-30/HCP-42 選購附件 OPTIONAL ACCESSORIES

1. C軸功能 C-axis function	7. 棒材自動送料機 Automatic bar feeder	13. Y軸側銑 (四軸) Y-axis side live tooling device (4-shaft)	19. 成品自動取料裝置 Parts catcher
2. 拉料器 Auto link (bar puller)	8. 油霧回收機 Oil mist collector	14. 簡易式單支送料架 Simple type single bar feeding device	20. 成品自動取料裝置含輸送帶 Parts catcher and conveyor belt
3. 變壓器 Transformer	9. 空調冷卻機 Air condition	15. 電動鏈板式鐵屑排出機 Electrical steel belt type chip conveyor	21. 主軸A2-4 Spindle A2-4
4. 穩壓器 Voltage stabilizer	10. CE規格 CE specification	16. 上方單軸側銑 Single shaft side live tooling device-Top	22. 主軸A2-5 Spindle A2-5
5. 主軸馬達7.5 HP Spindle motor 7.5 HP	11. 油水分離機 Oil skimmer	17. 下方單軸側銑 Single shaft side live tooling device-Below	23. 三軸端面鑽孔/攻牙裝置 End side live tooling device (3-shaft)
6. 主軸馬達10 HP Spindle motor 10 HP	12. 強力冷卻幫浦1HP 1HP powerful coolant pump	18. 立式銑刀裝置 Single shaft vertical type live tooling device	24. 角度型端銑裝置 (ER16) Angle-ajustable end milling device (45°)

機械規格 MACHINE SPECIFICATION

機型 MODEL		HC-30N
床面上旋徑 (mm)	Swing over cross bed	250
主軸馬達 (KW)	Spindle motor	3.75
主軸迴轉速 (rpm)	Spindle rotating speed	3200 (opt. 6000)
主軸貫穿孔徑 (mm)	Bore of spindle	Ø33
X,Z軸快速移動 (m/min)	Rapid travel speed (X-axis,Z-axis)	20
X,Z軸伺服馬達 (KW)	Servo motor (X-axis,Z-axis)	1
X軸螺桿外徑及導程 (mm)	X-axis Ballscrew	Ø25 pitch 10
Z軸螺桿外徑及導程 (mm)	Z-axis Ballscrew	Ø28 pitch 8
Z軸移動量 (mm)	Z-axis travel	200
X軸移動量 (mm)	X-axis travel	300
筒夾	Collet	C32
棒材容納直徑 (mm)	Max.bar feeding dia	Ø30
外徑刀尺寸 (mm)	O.D. tool size	□20
內徑刀尺寸 (mm)	I.D. turning tool size	Ø20
機器尺寸(長x寬x高) (mm)	Machine size (LxWxH)	1510x1550x1600
機械淨重 (kgs)	Machine net weight	1750

HC-30N 選購附件 OPTIONAL ACCESSORIES

1. 5"三爪夾頭 5" 3-jaws hydraulic chuck	6. 成品自動取料裝置 Parts catcher
2. 油壓缸檢知含集水槽 Hydraulicl cylinder detection device with coolant collector	7. 電動螺旋式鐵屑排出機 Electrical screw type chip conveyor
3. 強力冷卻幫浦1HP 1HP powerful coolant pump	8. CE規格 CE specification
4. 棒材自動送料機 Automatic bar feeder	9. 變壓器 Transformer
5. 8位伺服刀塔 8-position servo turret	

機械規格 MACHINE SPECIFICATION

機型 MODEL		HCS-25	HCS-32	HCS-25B	HCS-32B
棒材容納直徑 (mm)	Max. bar feeding dia.	Ø25	Ø32	Ø25	Ø32
主軸貫穿孔徑 (mm)	Bore of spindle	Ø28	Ø33	Ø28	Ø33
筒夾	Collet	星辰Citizen 25#	164E	星辰Citizen 25#	164E
導套座	Guide bush holder	星辰Citizen 25#	星辰Citizen 32#	(opt.)	
最大加工外徑 (mm)	Max. turning dia.	25	32	25	32
主軸內藏式馬達 (kw)	Spindle with built-in motor	3.75 (opt 5.5)		3.75 (opt 5.5)	
主軸迴轉速 (rpm)	Spindle rotating speed	6000		6000	
X.Y.Z軸伺服馬達 (kw)	Servo motor (X-axis.Y-axis.Z-axis)	1		1	
X軸移動量 (上下) (mm)	X-axis travel (vertical)	150		150	
Y軸移動量 (mm)	Y-axis travel	420		420	
Z軸移動量 無導套 (mm)	Without guide bush	310		310	
Z-axis travel(mm) 有導套 (mm)	With guide bush	180		180	
X.Y.Z軸快速移動 (m/min)	Rapid travel speed (X-axis.Y-axis.Z-axis)	25		25	
外徑刀具數	No. of O.D. turning tools	6		6	
外徑刀尺寸 (mm)	O.D. turning tool size	□16		□16	
內徑刀具數	No. of I.D. turning tools	5		5	
內徑刀尺寸 (mm)	I.D. turning tool size	Ø20		Ø20	
側/端銑伺服馬達 (kw)	Servo motor of cross/end side driving tool	2		2	
側/端銑伺服馬達轉速 (rpm)	Rotating speed of cross/end side live tooling	5000		5000	
側/端銑刀具規格	Size of cross/end side live tooling	ER-16/ER-20		ER-16/ER-20	
自動潤滑幫浦	Auto lubricator pump	3-6 cc/15 min		3-6 cc/15 min	
機器尺寸 (長x寬x高) mm	Machine size (LxWxH)	2100x1580x2000		2700x1580x2000	
機械淨重 (kgs)	Machine net weight	2400		3000	
副主軸 SUB SPINDLE					
最大加工外徑 (mm)	Max. turning dia.	-		25	32
副主軸馬達 (kw)	Sub-spindle motor	-		2.2 (opt 3.75)	
副主軸最高轉速 (rpm)	Max. rotating speed of sub-spindle	-		6000	
X.Z軸伺服馬達 (kw)	Servo motor (X-axis.Z-axis)	-		1	
X軸移動量 (mm)	X-axis travel	-		305	
Z軸移動量 (mm)	Z-axis travel	-		240	
X.Z軸快速移動 (m/min)	X.Z-axis rapid travel speed	-		25	
外徑刀具數	No. of O.D. turning tools	-		1	
外徑刀尺寸 (mm)	O.D. turning tool size	-		□16	
內徑刀具數	No. of I.D. turning tools	-		4	
內徑刀尺寸 (mm)	I.D. turning tool size	-		Ø20	

項目 ITEM	HCS-25B/32B 主軸動力刀具 SPINDLE LIVE TOOLING			
1. 側銑刀具數量與尺寸 No. & Size of cross side live tooling	4 pcs ER16	4. 端銑刀具數量與尺寸 (選配) Size of end side live tooling (opt.)	3 pcs ER20	
2. 側銑刀具伺服馬達 (kw) Servo motor of cross side live tooling	2	5. 端銑刀具伺服馬達 (KW) (選配) Servo motor of end side live tooling (opt.)	2	
3. 側銑刀具最高轉速 (rpm) Max. rotating speed of cross side live tooling	5000	6. 端銑刀具最高轉速 (rpm) (選配) Max. rotating speed of end side live tooling (opt.)	5000	

項目 ITEM	HCS-25B/32B 副主軸動力刀具 (選配) SUB-SPINDLE LIVE TOOLING (OPTIONAL)			
1. 端銑刀具數 No. of end side live tooling	4+(□16x1)	3. 端銑刀具尺寸 Size of end side live tooling	ER16	
2. 端銑刀具伺服馬達 (kw) Servo motor of end side live tooling	2	4. 端銑刀具最高轉速 (rpm) Rotating speed of end side live tooling	5000	

項目 ITEM	HCS-25B/32B 選購附件 OPTIONAL ACCESSORIES			
1. 穩壓器 Voltage stabilizer	6. 油霧回收機 Oil mist collector			
2. 強力冷卻幫浦1HP 1HP powerful coolant pump	7. CE規格 CE specification			
3. 電動鏈板式鐵屑排出機 Electrical steel belt type chip conveyor	8. 副主軸端銑四軸動力裝置 (ER16) End side live tooling device for sub-spindle (4-shaft)			
4. 同步迴轉導套 Synchronous rotary guide bushing device	9. 主軸端銑三軸動力裝置 (ER20) End side live tooling device for main spindle (3-shaft)			
5. 副主軸碟煞裝置 Disc brake for Sub-spindle				

項目 ITEM	HCS-25/32 選購附件 OPTIONAL ACCESSORIES			
1. 穩壓器 Voltage stabilizer	6. 輔助尾座 Auxiliary tailstock			
2. 電動鏈板式鐵屑排出機 Electrical steel belt type chip conveyor	7. 端面三軸動力裝置 (ER20) End side live tooling device (3-shaft)			
3. 長工件取料盒 Long workpiece collecting box	8. 油霧回收機 Oil mist collector			
4. 主軸導套 (走刀式固定座) Spindle guide bush (fixed guide bush holder)	9. CE規格 CE specification			
5. 主軸內孔襯套組 (PE) Spindle inner-hole bush (PE material) (set)				

JOA-252 機械規格 MACHINE SPECIFICATION

刀塔型式 TURRET TYPE		油壓刀塔 HYDRAULIC		動力刀塔 SERVO POWER	
床面上旋徑	Swing over cross bed (mm)			600	
過滑座蓋直徑	Over cross slide (mm)			390	
最大加工外徑	Max turning dia (mm)			350	
最大加工長度	Max machining length (mm)			600 (option 900/1200)	
拉管通孔徑	Hole through draw bar (mm)			52	
夾頭尺寸	Chuck size (inch)			8"	
主軸馬達	Spindle motor (kw)			11/15	
主軸最大轉速	Max. Spindle speed (rpm)			4000	
主軸鼻端	Spindle nose (asa)			A2-6	
主軸通孔徑	Spindle bore (mm)			62	
主軸前軸承內徑	Front bearing inside dia (mm)			100	
Z軸行程	Z axis travel (mm)			600 (option 900/1200)	
X軸行程	X axis travel (mm)	200			260
Z軸馬達	Z axis motor (kw)	1.8			2.5
X軸馬達	X axis motor (kw)	1.8			2.5
總電力需求	Electrical power supply (kva)	22			30
Z軸快速進給	Z axis rapid feed (m/min)			20	
X軸快速進給	X axis rapid feed (m/min)			20	
軌道型式	Guid ways	硬軌 Box way			
刀塔型式	Turret type	油壓 Hydraulic		動力伺服 Servo power	
刀塔數量	Number of tools	10T		12T	
動力刀座轉速	Live tooling speed (rpm)	-		6000	
轉動刀軸馬達	Live tooling speed (kw)	-		2.2/3.7	
外徑刀尺寸	Size of O.D.turning tool (mm)	□25		VDI 30. □20	
內徑刀尺寸	Size of I.D turning tools (mm)	Ø40		VDI 30. Ø32	
尾座心軸直徑	Quill dia (mm)			80	
尾座心軸行程	Quill stroke (mm)			100	
尾座本體行程	Tailstock travel (mm)			600 (option 900/1200)	
心軸套筒錐度	Quill taper (mm)			MT#4	
佔地面積	Occupancy (LxWxH) (mm)	3700 (600L)/4000 (900L)/4300 (1200L) X 1845 X 2075			
機械淨重	Machine net weight (kgs)	4200			

標準附件 STANDARD ACCESSORIES

項目 ITEM

A2-6 8" 三爪油壓夾盤含軟爪	一組	手動油壓尾座	一組
A2-6 8" 3-jaw hydraulic chuck including soft jaw	1 set	Hydraulic tailstock	1 set
腳踏開關	一組	自動潤滑系統	一組
Foot switch	1 set	Auto lubricant system	1 set
工具及工具箱	一組	工作燈	一組
Tools & tool box	1 set	Lighting device	1 set
機械墊塊	六個	強力冷卻幫浦 1HP	一組
Base leveling block	6 pcs	1HP powerful coolant pump	1 set
切削液設備	一組	電動鏈板式鐵屑排出機	一組
Coolant device	1 set	Electrical steel belt type chip conveyor	1 set
JOA-252 十位置油壓刀塔 10-position hydraulic turret (LS-160A)	內孔刀座 (I.D Ø40) Tool base for inner hole 5 sets 車刀墊片 (上、下) □25 Tool spacer(up,down) 5 sets 內孔套筒 (I.D Ø8,10,12,16,20,25,32)O.D.Ø40 各一 Tool holder bush for inner hole 1 pc / each	JOA-252 十二位置伺服動力刀塔 12-position servo power turret (VDI30-Coupling DIN 1809)	外徑刀座 □20 Tool base for O.D. 3 pcs 內孔刀座 (I.D Ø32) Tool base for inner hole 3 sets 內孔套筒 (I.D Ø8,10,12,16,20,25)O.D Ø32 各一 Tool holder bush for inner hole 1 pc / each 保護套 七個 Protective cap 7 pcs

選購附件 OPTIONAL ACCESSORIES

項目 ITEM

1. 手動刀具量測 Manual tool measurement	6. PLC可程式控制尾座 Programmable tailstock	11. 筒夾套 Ø60 Collet chuck Ø60
2. 油霧回收機 Oil-mist collector	7. 油水分離機 Oil skimmer	12. 10" 三爪油壓夾頭 10" 3-jaw hydraulic chuck (A2-8 spindle)
3. 棒材自動送料機 Auto bar feeder	8. 變壓器 Transformer	13. 12位伺服動力刀塔 12-position servo power turret
4. 空調冷卻機 Air condition	9. 穩壓器 Voltage stabilizer	
5. 成品取料裝置及輸送帶 Parts catcher and conveyor	10. CE規格 CE specification	



Официальный дистрибьютор в России компании Greenway

<http://stanok-park.ru/>

Ростов-на-Дону, Шолохова 58/80

8-800-500-13-45

+7(863) 247-01-08

stanok-park@bk.ru